



HALO

GRADE 43 HIGH TEST CHAIN

NOT APPROVED FOR OVERHEAD LIFTING



| Chain Trade Size | Material Diameter (in.) | Nominal Inside Length (in.) | Nominal Inside Width (in.) | Max. Weight Per 100 Ft. (lbs.) | W.L.L. (lbs.) | Feet Per Drum | Country of Origin |
|------------------|-------------------------|-----------------------------|----------------------------|--------------------------------|---------------|---------------|-------------------|
| 1/4" | 0.274 | 1.236 | 0.48 | 65 | 2600 | 800 | USA |
| 5/16" | 0.334 | 1.12 | 0.48 | 103 | 3900 | 550 | USA |
| 3/8" | 0.392 | 1.374 | 0.551 | 140 | 5400 | 400 | USA |
| 1/2" | 0.51 | 1.782 | 0.75 | 234 | 9200 | 200 | USA |
| 5/8" | 0.625 | 2.016 | 0.851 | 375 | 13000 | 150 | USA |



⚠ Never Exceed Working Load Limit

GRADE 70 TRANSPORT CHAIN

NOT APPROVED FOR OVERHEAD LIFTING



| Chain Trade Size | Material Diameter (in.) | Nominal Inside Length (in.) | Nominal Inside Width (in.) | Max. Weight Per 100 Ft. (lbs.) | W.L.L. (lbs.) | Feet Per Drum | Country of Origin |
|------------------|-------------------------|-----------------------------|----------------------------|--------------------------------|---------------|---------------|-------------------|
| 1/4" | 0.274 | 1.236 | 0.48 | 65 | 3150 | 800 | USA |
| 5/16" | 0.334 | 1.12 | 0.48 | 103 | 4700 | 550 | USA |
| 3/8" | 0.392 | 1.374 | 0.551 | 140 | 6600 | 400 | USA |
| 1/2" | 0.51 | 1.782 | 0.75 | 234 | 11300 | 200 | USA |
| 5/8" | 0.625 | 2.016 | 0.851 | 375 | 15800 | 150 | USA |



⚠ Never Exceed Working Load Limit

GRADE 80 & 100 ALLOY CHAIN



⚠ Never Exceed Working Load Limit

| Chain Trade Size | Material Diameter (in.) | Nominal Inside Length (in.) | Nominal Inside Width (in.) | Max. Weight Per 100 Ft. (lbs.) | GRADE 80 W.L.L. (lbs.) | GRADE 100 W.L.L. (lbs.) | Feet Per Drum | Country of Origin |
|------------------|-------------------------|-----------------------------|----------------------------|--------------------------------|------------------------|-------------------------|---------------|-------------------|
| 9/32" | 0.279 | 0.87 | 0.405 | 77 | 3500 | 4300 | 800 | USA |
| 5/16" | 0.343 | 1.01 | 0.49 | 112 | 5350 | 5700 | 500 | USA |
| 3/8" | 0.404 | 1.226 | 0.56 | 152 | 7100 | 8800 | 500 | USA |
| 1/2" | 0.529 | 1.57 | 0.75 | 266 | 12000 | 15000 | 300 | USA |
| 5/8" | 0.625 | 1.93 | 0.865 | 360 | 18100 | 22600 | 200 | USA |
| 3/4" | 0.787 | 2.42 | 1.04 | 621 | 28300 | | 100 | Italy |
| 7/8" | 0.881 | 2.7 | 1.28 | 760 | 34200 | | 100 | Italy |
| 1" | 1 | 2.8 | 1.4 | 953 | 47700 | | 50 | Italy |
| 1-1/4" | 1.25 | 3.5 | 1.75 | 1537 | 72300 | | 50 | Italy |





GRADE 30 PROOF COIL - BRIGHT & GALVANIZED

HALO

Imported

**NOT APPROVED FOR
OVERHEAD LIFTING**



Never Exceed Working Load Limit

| Chain Size | Inside Length (in.) | Inside Width (in.) | Wt. per ft. (lbs.) | Working Load Limit (lbs.) | ft. per drum |
|------------|---------------------|--------------------|--------------------|---------------------------|--------------|
| 3/16" | 0.95 | 0.40 | 0.33 | 800 | 800 |
| 1/4" | 1.00 | 0.58 | 0.56 | 1300 | 800 |
| 5/16" | 1.29 | 0.44 | 0.93 | 1900 | 550 |
| 3/8" | 1.23 | 0.62 | 1.38 | 2650 | 400 |
| 1/2" | 1.54 | 0.80 | 2.41 | 4500 | 200 |
| 5/8" | 2.20 | 0.87 | 3.51 | 6900 | 150 |
| 3/4" | 2.76 | 1.06 | 5.51 | 10600 | 100 |

GRADE 30 PROOF COIL - GALVANIZED LONG LINK

DOCK AND FENDER APPLICATIONS



Never Exceed Working Load Limit

Imported

**NOT APPROVED FOR
OVERHEAD LIFTING**

| Chain Size | Inside Length (in.) | Inside Width (in.) | Wt. per ft. (lbs.) | Working Load Limit (lbs.) | ft. per drum |
|------------|---------------------|--------------------|--------------------|---------------------------|--------------|
| 1/2" | 2.27 | 0.87 | 2.22 | 4500 | 200 |
| 5/8" | 2.56 | 1.00 | 3.41 | 6900 | 150 |
| 3/4" | 4.49 | 1.15 | 4.20 | 10600 | 100 |

GRADE 43 HIGH TEST - BRIGHT



Never Exceed Working Load Limit

Imported

**NOT APPROVED FOR
OVERHEAD LIFTING**

| Chain Size | Inside Length (in.) | Inside Width (in.) | Wt. per ft. (lbs.) | Working Load Limit (lbs.) | ft. per drum |
|------------|---------------------|--------------------|--------------------|---------------------------|--------------|
| 1/4" | 1.00 | 0.58 | 0.56 | 2600 | 800 |
| 5/16" | 1.29 | 0.44 | 0.93 | 3900 | 550 |
| 3/8" | 1.23 | 0.62 | 1.38 | 5400 | 400 |
| 1/2" | 1.54 | 0.80 | 2.41 | 9200 | 200 |
| 5/8" | 2.20 | 0.87 | 3.51 | 13000 | 150 |

GRADE 30 STAINLESS STEEL - TYPE 304 & 316 SS

NACM Standard



Never Exceed Working Load Limit

Imported

**NOT APPROVED FOR
OVERHEAD LIFTING**

| Chain Size | Inside Length (in.) | Inside Width (in.) | Wt. per ft. (lbs.) | Working Load Limit (lbs.) |
|------------|---------------------|--------------------|--------------------|---------------------------|
| 1/8" | 0.75 | 0.26 | 0.17 | 620 |
| 3/16" | 0.92 | 0.34 | 0.38 | 930 |
| 1/4" | 1.00 | 0.43 | 0.61 | 1570 |
| 5/16" | 1.03 | 0.49 | 0.84 | 2400 |
| 3/8" | 1.22 | 0.61 | 1.4 | 3550 |
| 1/2" | 1.50 | 0.78 | 2.34 | 5400 |



HALO

BINDER CHAINS



Made in USA.

| Grade 43 High Test Binder Chains | | | | |
|----------------------------------|--------|---------------|-------------------|-----------------|
| Chain Size | Length | W.L.L. (lbs.) | Weight Ea. (lbs.) | Pieces per drum |
| 3/8" | 20' | 5400 | 29 | 25 |



Never Exceed Working Load Limit

| Grade 70 Transport Binder Chains | | | | |
|----------------------------------|--------|---------------|-------------------|-----------------|
| Chain Size | Length | W.L.L. (lbs.) | Weight Ea. (lbs.) | Pieces per drum |
| 5/16" | 20' | 4700 | 21 | 25 |
| 3/8" | 20' | 5400 | 30 | 25 |



GRADE 80 WINCH TAIL CHAINS



Never Exceed Working Load Limit

| Size (in.) | Approx. Length Excluding Hook (in.) | Working Load Limit (lbs.) | No. of Links | Wt. Ea. (lbs.) |
|------------|-------------------------------------|---------------------------|--------------|----------------|
| 3/4 x 18 | 19-5/8 | 28,300 | 8 | 14 |
| 7/8 x 24 | 24 | 34,200 | 9 | 23 |
| 1 x 24 | 20-3/8 | 47,400 | 7 | 24 |

Chain specifications



| | Chain size | | Working load limit (lbs.)* | Nominal inside link dimensions (inches) | | Weight per 100 ft. (lbs.) |
|--|------------|---------|----------------------------|---|-------|---------------------------|
| | Inches | Decimal | | Length | Width | |
| CM GRADE 30 PROOF COIL CHAIN | 3/16 | .218 | 800 | .95 | .40 | 38 |
| | 1/4 | .276 | 1,300 | 1.00 | .47 | 66 |
| | 5/16 | .327 | 1,900 | 1.10 | .50 | 98 |
| | 3/8 | .390 | 2,650 | 1.23 | .62 | 144 |
| | 7/16 | .468 | 3,700 | 1.37 | .75 | 210 |
| | 1/2 | .531 | 4,500 | 1.50 | .81 | 278 |
| | 5/8 | .656 | 6,900 | 1.87 | 1.00 | 422 |
| | 3/4 | .787 | 10,600 | 2.12 | 1.12 | 628 |
| CM GRADE 43 HIGH TEST CHAIN | 1 | 1.031 | 17,900 | 2.75 | 1.50 | 1,069 |
| | 1/4 | .281 | 2,600 | 1.00 | .47 | 71 |
| | 5/16 | .327 | 3,900 | 1.10 | .50 | 98 |
| | 3/8 | .390 | 5,400 | 1.23 | .62 | 144 |
| | 7/16 | .468 | 7,200 | 1.37 | .75 | 210 |
| | 1/2 | .531 | 9,200 | 1.50 | .81 | 278 |
| | 5/8 | .656 | 13,000 | 1.87 | 1.00 | 422 |
| | 3/4 | .781 | 20,200 | 2.12 | 1.12 | 606 |
| CM GRADE 70 TRANSPORT (BINDING) CHAIN | 7/8 | .875 | 24,500 | 2.25 | 1.14 | 776 |
| | 1 | 1.000 | 34,100 | 2.75 | 1.50 | 1,050 |
| | 1/4 | .281 | 3,150 | .84 | .47 | 74 |
| | 5/16 | .327 | 4,700 | .98 | .46 | 100 |
| | 3/8 | .406 | 6,600 | 1.14 | .54 | 156 |
| | 7/16 | .468 | 8,750 | 1.33 | .62 | 204 |
| | 1/2 | .531 | 11,300 | 1.43 | .72 | 259 |

Dimensions and weights are approximate and subject to variations.

CM Welded graded chain

Welded graded chain is an industrial grade chain used extensively in rigging, towing and overhead lifting applications. CM graded chains are manufactured in accordance with the NACM Specification for chain, ASTM Standard A391 and ASTM Standard A413. The standardized grade designations are 30, 43 and 70 for carbon steel chain, and 63 and 80 for alloy steel chain. The grade number relates to the strength

level of the chain, with the grade number increasing as the strength of the chain increases.

Only Herc-Alloy 800 and Herc-Alloy 63 chain is designed for overhead lifting. The other grade designated chains are not made from alloy steel and should not be used for overhead lifting.

***⚠️ WARNING**

- Do not exceed working load limit.
- Use only alloy chain and attachments for overhead lifting.

CM grade 30 proof coil chain

Embossed: G30 and date codes
packed in continuous lengths in half
drum, standard drum and large drum.



| Chain size (in.) | Standard drum pack (600 lbs.) | | | | | | Feet per container Std. drum | Max. weight per 100 ft. (lbs.) |
|------------------|-------------------------------|------------|--------------|------------|-----------------|------------|---------------------------------|--------------------------------|
| | Self colored | | Zinc plated | | Hot galvanized‡ | | | |
| | Product code | UPC 43927- | Product code | UPC 43927- | Product code | UPC 43927- | | |
| 3/16 | 671040 | 28059 | 671440 | 30004 | 671340 | 29366 | 850 | 38 |
| 1/4 | 671041 | 28173 | 671441 | 30080 | 671341 | 29404 | 800 | 66 |
| 5/16 | 671042 | 28457 | 671442 | 30188 | 671342 | 29454 | 550 | 98 |
| 3/8 | 671043 | 28690 | 671443 | 30220 | 671343 | 29519 | 400 | 144 |
| 7/16 | 671044 | 20068 | — | — | — | — | 300 | 210 |
| 1/2 | 671045 | 28936 | 671445 | 30363 | 671345 | 29678 | 200 | 278 |
| 5/8 | 671046 | 29179 | — | — | 671346 | 29705 | 150 | 422 |
| 3/4 | 671047 | 29277 | — | — | 671347 | 29802 | 100 | 628 |
| 1 | 671049 | 20247 | — | — | — | — | 60 | 1,069 |

| Chain size (in.) | Pailpak packed in plastic pails | | | | | | | | Display reels | | | | | | | |
|------------------|---------------------------------|------------|--------------|------------|-----------------|------------|---------------|-----------------------------|---------------|------------|---------------|--------------------------------|----------------|------------|---------------|--------------------------------|
| | Self colored | | Zinc plated | | Hot galvanized‡ | | Feet per pail | Approx. gross weight (lbs.) | Zinc plated | | Feet per reel | Approx. weight per reel (lbs.) | Hot galvanized | | Feet per reel | Approx. weight per reel (lbs.) |
| | Product code | UPC 43927- | Product code | UPC 43927- | Product code | UPC 43927- | | | Product code | UPC 43927- | | | Product code | UPC 43927- | | |
| 3/16 | 671010 | 28058 | 671410 | 71410 | 671310 | 29375 | 250 | 95 | 671430 | 71430 | 100 | 38 | 671330 | 29376 | 100 | 38 |
| 1/4 | 671011 | 28172 | 671411 | 71411 | 671311 | 29402 | 141 | 93 | 671431 | 71431 | 75 | 48 | 671331 | 29403 | 75 | 50 |
| 5/16 | 671012 | 28456 | 671412 | 71412 | 671312 | 29452 | 92 | 93 | 671432 | 71432 | 55 | 55 | 671332 | 29453 | 55 | 69 |
| 3/8 | 671013 | 28689 | 671413 | 71413 | 671313 | 29517 | 63 | 94 | 671433 | 71433 | 35 | 51 | 671333 | 29518 | 35 | 58 |
| 1/2 | 671015 | 28935 | 671415 | 30362 | 671315 | 29677 | 40 | 114 | — | — | — | — | — | — | — | — |

‡Weight for hot galvanized: Add 5% for sizes under 1/2". Add 2% for sizes over 1/2".

| Chain size (in.) | Half drum pack (300 lbs.) | | | | | | Feet per container Large drum | Mfg. weight per 100 ft. (lbs.) |
|------------------|---------------------------|------------|--------------|------------|----------------|------------|----------------------------------|--------------------------------|
| | Self colored | | Zinc plated | | Hot galvanized | | | |
| | Product code | UPC 43927- | Product code | UPC 43927- | Product code | UPC 43927- | | |
| 3/16 | 671094 | 28061 | 671494 | 30007 | 671394 | 29368 | 500 | 38 |
| 1/4 | 671091 | 28175 | 671491 | 30081 | 671391 | 29406 | 400 | 66 |
| 5/16 | 671092 | 28459 | 671492 | 30190 | 671392 | 29456 | 275 | 98 |
| 3/8 | 671093 | 28692 | 671493 | 30222 | 671393 | 29521 | 200 | 144 |
| 1/2 | — | — | — | — | 671395 | 29680 | 100 | 278 |

| Chain size (in.) | Large drum pack (1000 lbs.) | | | | | | Feet per container Large drum | Mfg. weight per 100 ft. (lbs.) |
|------------------|-----------------------------|------------|--------------|------------|----------------|------------|----------------------------------|--------------------------------|
| | Self colored | | Zinc plated | | Hot galvanized | | | |
| | Product code | UPC 43927- | Product code | UPC 43927- | Product code | UPC 43927- | | |
| 3/16 | 671060 | 28060 | 671480 | 30006 | 671360 | 29367 | 1500 | 38 |
| 1/4 | 671061 | 28174 | 671481 | 30085 | 671361 | 29405 | 1400 | 66 |
| 5/16 | 671062 | 28458 | 671482 | 30191 | 671362 | 29455 | 900 | 98 |
| 3/8 | 671063 | 28691 | 671483 | 30221 | 671363 | 29520 | 650 | 144 |
| 1/2 | 671065 | 28937 | — | — | 671365 | 29679 | 350 | 278 |
| 5/8 | 671066 | 29180 | — | — | 671366 | 29706 | 250 | 422 |
| 3/4 | 671067 | 29278 | — | — | 671367 | 29803 | 170 | 628 |
| 1 | 671069 | 29299 | — | — | 671369 | 29902 | 100 | 1,069 |

CM grade 43 high test chain

Embossed: G43 and date code packed in continuous lengths in half drum, standard and large drums.

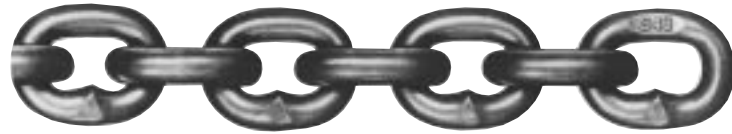

Drum pack

| Chain size (in.) | Bright finish | | | | | | Hot galvanized‡ | | | | | | Max. weight per 100 ft. (lbs.) | |
|------------------|---------------|------------|--------------|------------|--------------|------------|-----------------|------------|--------------|------------|--------------------|-----------|--------------------------------|------------|
| | Half drum | | Std. drum | | Large drum | | Half drum | | Std. drum | | Feet per container | | | |
| | Product code | UPC 43927- | Product code | UPC 43927- | Product code | UPC 43927- | Product code | UPC 43927- | Product code | UPC 43927- | Half drum | Std. drum | | Large drum |
| 1/4 | 678131 | 24637 | 678141 | 24638 | 678161 | 24639 | 678331 | 25120 | 678341 | 24640 | 400 | 800 | 1,400 | 71 |
| 5/16 | 678132 | 24810 | 678142 | 24811 | 678162 | 24812 | 678332 | 27116 | 678342 | 24813 | 275 | 550 | 900 | 98 |
| 3/8 | 678133 | 25111 | 678143 | 25112 | 678163 | 25113 | 678333 | 25114 | 678343 | 25115 | 200 | 400 | 650 | 144 |
| 7/16 | 678134 | 20070 | 678144 | 25325 | — | — | — | — | — | — | 150 | 300 | — | 210 |
| 1/2 | 678135 | 25414 | 678145 | 25415 | 678165 | 25416 | 678335 | 27441 | 678345 | 25417 | 100 | 200 | 350 | 278 |
| 5/8 | 678136 | 25579 | 678146 | 25580 | 678166 | 25581 | 678336 | 25582 | 678346 | 22913 | 75 | 150 | 250 | 422 |
| 3/4 | 678137 | 26715 | 678147 | 26716 | 678167 | 26717 | 678337 | 25583 | 678347 | 26718 | 50 | 100 | 170 | 606 |
| 7/8 | 678138 | 23032 | 678148 | — | — | — | — | — | — | — | 40 | 80 | — | 776 |
| 1 | 678139 | 23034 | 678149 | 20552 | — | — | — | — | — | — | 30 | 60 | — | 1,050 |

Pailpak packed in plastic pails

Display reels

| Chain size (in.) | Self colored | | Zinc plated | | Hot galvanized‡ | | Feet per pail | Approx. gross weight (lbs.) | Zinc plated | | Feet per reel | Approx. weight per reel (lbs.) |
|------------------|--------------|------------|--------------|------------|-----------------|------------|---------------|-----------------------------|--------------|------------|---------------|--------------------------------|
| | Product code | UPC 43927- | Product code | UPC 43927- | Product code | UPC 43927- | | | Product code | UPC 43927- | | |
| 1/4 | 678111 | 24636 | 678411 | 24642 | 678311 | 27990 | 130 | 92 | 678421 | 24643 | 75 | 53 |
| 5/16 | 678112 | 24809 | 678412 | 24815 | 678312 | 28468 | 90 | 88 | 678422 | 24816 | 70 | 69 |
| 3/8 | 678113 | 25110 | 678413 | 25117 | 678313 | 28676 | 64 | 92 | 678423 | 25118 | 45 | 65 |

‡Weight for hot galvanized: Add 5% for sizes under 1/2". Add 2% for sizes over 1/2".

CM grade 70 transport (binding) chain

Embossed: G70 (gold finish) and trace code packed in continuous lengths in half drum, standard and large drums.

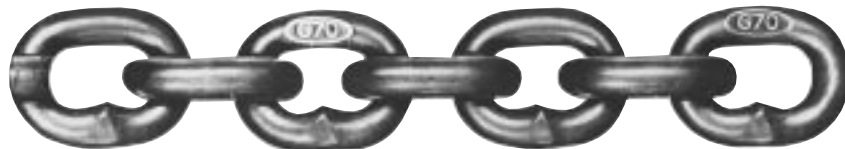

Drum pack

Pailpak packed in plastic pails

| Chain size (in.) | Half drum | | Std. drum | | Large drum | | Feet per container | | | Weight per 100 ft. (lbs.) | Pailpak packed in plastic pails | | | |
|------------------|--------------|------------|--------------|------------|--------------|------------|--------------------|-----------|------------|---------------------------|---------------------------------|------------|-------------------------|------------------------|
| | Product code | UPC 43927- | Product code | UPC 43927- | Product code | UPC 43927- | Half drum | Std. drum | Large drum | | Product code | UPC 43927- | Feet per pail (approx.) | Gross weight (approx.) |
| 1/4 | 678521 | 32636 | 678531 | 32637 | 678541 | 32638 | 400 | 800 | 1,400 | 74 | 678517 | 21877 | 130 | 96 |
| 5/16 | 678522 | 32798 | 678532 | 32799 | 678542 | 32800 | 275 | 550 | 900 | 100 | 678518 | 21878 | 90 | 91 |
| 3/8 | 678523 | 32834 | 678533 | 32835 | 678543 | 32837 | 200 | 400 | 650 | 156 | 678519 | 21879 | 64 | 101 |
| 7/16 | 678524 | 32905 | 678534 | 32906 | 678544 | 32907 | 150 | 300 | 450 | 204 | — | — | — | — |
| 1/2 | 678525 | 33029 | 678535 | 33030 | 678545 | 33031 | 100 | 200 | 350 | 259 | — | — | — | — |

Log chains/grade 30 proof coil chain with or without swivel



| Size | Working load limit (lbs.)* | With swivel | | Without swivel | | Approx. weight (lbs.) |
|-------------|----------------------------|--------------|------------|----------------|------------|-----------------------|
| | | Product code | UPC 43927- | Product code | UPC 43927- | |
| 5/16" x 14' | 1,900 | 609308 | 20747 | 609350 | 20748 | 16 |
| 3/8" x 14' | 2,650 | 609314 | 20746 | 609356 | 20749 | 23 |

Description: Self colored. Fitted with grab hook at one end and slip hook at the other end. Packed in carton.

* ⚠ WARNING

TO AVOID INJURY:

- Do not exceed working load limit.
- Use only alloy chain and attachments for overhead lifting.

CM binder chain assemblies

Used by truckers, contractors, oil field crews, highway crews and farmers.



Eye grab hook

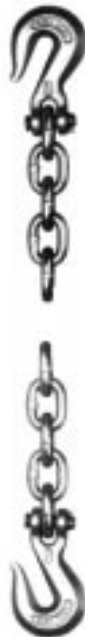

Clevis grab hook

Eye grab hook

| Size (in.) | Product code | Grade 43 | | | Grade 70 | | |
|------------|--------------|------------|----------------------------|--------------|------------|----------------------------|--|
| | | UPC 43927- | Working load limit (lbs.)* | Product code | UPC 43927- | Working load limit (lbs.)* | |
| 5/16 x 14 | 638228** | 38228 | 3,900 | 638259** | 33301 | 4,700 | |
| 5/16 x 16 | 638229** | 33855 | 3,900 | 638264** | 33303 | 4,700 | |
| 5/16 x 18 | 638230** | 33856 | 3,900 | — | — | — | |
| 5/16 x 20 | 638231** | 27117 | 3,900 | 638224 | 33300 | 4,700 | |
| 5/16 x 25 | — | — | — | 638306** | 33314 | 4,700 | |
| 3/8 x 12 | 638227 | 33857 | 5,400 | — | — | — | |
| 3/8 x 14 | 638239 | 27448 | 5,400 | — | — | — | |
| 3/8 x 16 | 638240 | 27449 | 5,400 | — | — | — | |
| 3/8 x 18 | 638242 | 27451 | 5,400 | — | — | — | |
| 3/8 x 20 | 638241 | 27450 | 5,400 | — | — | — | |
| 3/8 x 25 | 638232 | 33858 | 5,400 | — | — | — | |

Sizes not coded can be furnished upon request.
 **Standard packaging 1 per bag. Others bulk.
 All can be furnished bulk or bagged upon request.

Clevis grab hook

| Size (in.) | Product code | Grade 43 | | | Grade 70 | | |
|------------|--------------|------------|----------------------------|--------------|------------|----------------------------|--|
| | | UPC 43927- | Working load limit (lbs.)* | Product code | UPC 43927- | Working load limit (lbs.)* | |
| 5/16 x 14 | — | — | — | 638281 | 33309 | 4,700 | |
| 5/16 x 16 | — | — | — | 638282 | 33310 | 4,700 | |
| 5/16 x 18 | — | — | — | 638283 | 33311 | 4,700 | |
| 5/16 x 20 | — | — | — | 638284 | 33312 | 4,700 | |
| 5/16 x 25 | — | — | — | 638279 | 33308 | 4,700 | |
| 3/8 x 12 | 638215 | 33859 | 5,400 | — | — | — | |
| 3/8 x 14 | 638216 | 31888 | 5,400 | 638291 | 33860 | 6,600 | |
| 3/8 x 16 | 638217 | 38217 | 5,400 | 638292 | 33488 | 6,600 | |
| 3/8 x 18 | 638218 | 27442 | 5,400 | 638293 | 33489 | 6,600 | |
| 3/8 x 20 | 638219 | 27443 | 5,400 | 638294 | 33490 | 6,600 | |
| 3/8 x 25 | 638220 | 27444 | 5,400 | — | — | 6,600 | |
| 1/2 x 18 | — | — | — | — | — | — | |
| 1/2 x 20 | — | — | — | — | — | — | |

Sizes not coded can be furnished upon request.
 All can be furnished bulk or bagged upon request.

*** ⚠ WARNING**

Death/injury can occur from improper use or maintenance of tie-down equipment.

TO AVOID INJURY:

- Inspect before use. Remove from service if cracked, worn, or deformed.
- Do not overload. Load binders develop approximate working load with hand effort.
- Do not use handle extender on load binder(s).
- Do not use binder components for overhead lifting.

CM dock fender/deck lashing chain

A long link heat treated high strength chain designed for marine use—cargo lashing or dock fendering. Extra inside length designed to accept shackles. Supplied self colored or hot dip gvanized.

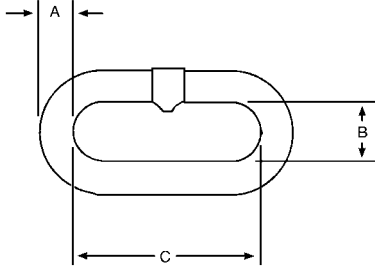

| Dia. (in.) A | Inside dimensions | | Product code | UPC 43927- | Finish | Min. breaking strength (lbs.) | Wt./ft. |
|-----------------|-------------------|-------|--------------|------------|--------|-------------------------------|---------|
| | B | C | | | | | |
| 1/2 | .950 | 3.735 | 695653 | 33850 | S/C | 50,000 | 1.85 |
| 1/2 | .944 | 3.729 | 695658 | 33854 | Galv. | 35,000 | 2.00 |
| 5/8 | .921 | 3.5 | 695663 | 33892 | S/C | 54,000 | 3.2 |
| 5/8 | .922 | 3.75 | 695667 | 33896 | Galv. | 54,000 | 3.17 |
| 3/4 | 1.625 | 4.00 | 695678 | 33900 | Galv. | 77,000 | 4.91 |
| 3/4 | 1.125 | 3.75 | 695675 | 33898 | Galv. | 75,000 | 4.45 |
| 1 | 1.18 | 3.62 | 695729 | 22983 | S/C | 170,000 | 9.9 |

Draglink chain

A long link, heat treated through hardened chain used in the trawling/fishing industry. Finish—black phosphate.

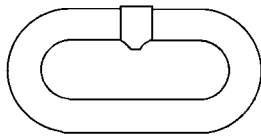

| Size (in.) | Working load limit (lbs.) | Inside dimensions | Product code | UPC 43927- | Feet per drum | Weight per 100 ft. (lbs.) |
|------------|---------------------------|-------------------|--------------|------------|---------------|---------------------------|
| 3/8 | 6,200 | .656 x 2.2 | 695026 | 33945 | 200 | 124 |
| 1/2 | 10,600 | .937 x 2.0 | 695027 | 33961 | 200 | 247 |
| 5/8 | 16,150 | .915 x 2.53 | 695028 | 33985 | 200 | 371 |

Scallop/sweep chain—grade 70

A high strength, through hardened chain used for scalloping in the marine/fishing industry. Finish—black phosphate.

| Size (in.) | Inside dimensions | Product code | UPC 43927- | Feet per drum | Weight per 100 ft. (lbs.) |
|------------|-------------------|--------------|------------|---------------|---------------------------|
| 5/8 | .98 x 2.25 | 671646 | 34014 | 150 | 577 |

Debarking/delimiting flail chain

A through hardened steel chain with optimum wear resistance for peak performance. Available in cut lengths natural finish.

| Size (in.) | Inside dimensions | Product code | UPC 43927- | Weight per 100 ft. (lbs.) |
|------------|-------------------|----------------------|------------|---------------------------|
| 5/8 | .962 x 1.68 | 697001 (normal weld) | 20699 | 393 |
| 5/8 | .962 x 1.68 | 697201 (full trim) | 20434 | 393 |

Tow truck chain assemblies and attachments

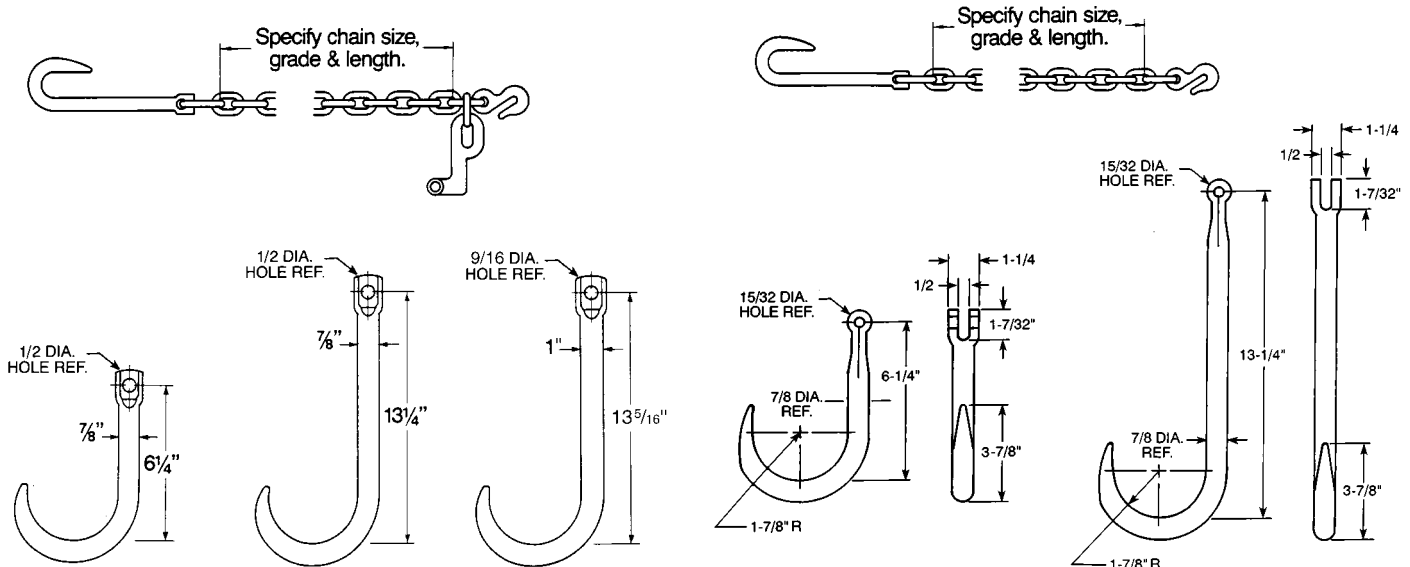

J hook
Sports car
Product code
D90217Z

J hook
Standard
Product code
D92800Z

J hook
Heavy duty
Product code
M92801Z

J hook
Sports car—
clevis type
Product code
D90243

J hook
Standard—
clevis type
Product code
D90283

Other custom tow truck chain assemblies available.

CM lever type load binder

- Provides more control in binding and releasing without extra tools.
- Handle closes down away from load with more leverage.
- Functionally superior to any other on the road.
- Handles are drop forged from special bar quality steel.
- Hooks are heat treated steel.
- Single welded links as in binder chain for better reliability.
- More take-up for binding greater loads. Smaller handle slot with riveted nose to prevent spreading at the critical loading point.
- Meets D.O.T. and C.V.S.A. requirements.

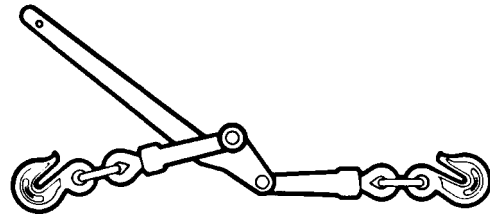

| Chain size (in.) | Chain grade | Working load limit (lbs.)* | Product code | UPC 43927- | Handle length (in.) | Take-up (in.) | Approx. weight each (lbs.) |
|------------------|-------------|----------------------------|--------------|------------|---------------------|---------------|----------------------------|
| 1/4 | G30, 43 | 2,600 | M104 | 42642 | 11 1/4 | 3 | 2 1/2 |
| 1/4 | G30, 43, 70 | 5,400 | M105 | 42644 | 16 | 4 7/8 | 8 1/4 |
| 5/16 | G30, 43, 70 | 5,400 | M105 | 42644 | 16 | 4 7/8 | 8 1/4 |
| 3/8 | G30, 43 | 5,400 | M105 | 42644 | 16 | 4 7/8 | 8 1/4 |
| 5/16 | G30, 43, 70 | 9,200 | M106 | 42647 | 18 1/2 | 5 1/8 | 11 1/4 |
| 3/8 | G30, 43, 70 | 9,200 | M106 | 42647 | 18 1/2 | 5 1/8 | 11 1/4 |
| 7/16 | G30, 43 | 9,200 | M106 | 42647 | 18 1/2 | 5 1/8 | 11 1/4 |
| 1/2 | G30, 43 | 9,200 | M106 | 42647 | 18 1/2 | 5 1/8 | 11 1/4 |

CM claw hook load binder

- Same reliable design and construction as lever type load binder.
- Equipped with claw hooks for easy one-handed connection to loose or taut chain.
- Meets D.O.T. and C.V.S.A. requirements.

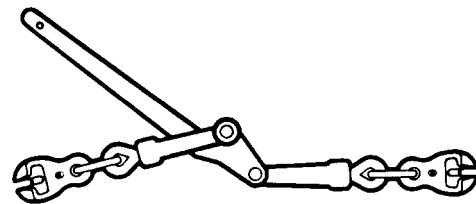

| Chain size (in.) | Chain grade | Working load limit (lbs.)* | Product code | UPC 43927- | Handle length (in.) | Take-up (in.) | Approx. weight each (lbs.) |
|------------------|-------------|----------------------------|--------------|------------|---------------------|---------------|----------------------------|
| 1/4 | G30, 43, 70 | 5,400 | M105C | 42645 | 16 | 4 7/8 | 8 1/2 |
| 5/16 | G30, 43, 70 | 5,400 | M105C | 42645 | 16 | 4 7/8 | 8 1/2 |
| 3/8 | G30, 43 | 5,400 | M105C | 42645 | 16 | 4 7/8 | 8 1/2 |

Load binder operating instructions

1. Follow D.O.T. Federal Motor Carrier Safety Regulations S 392.9, S 393.100, and S 393.102.
2. Inspect before use. Replace worn and deformed binders. Lubricate pivot and swivel points for optimum performance.
3. Do not operate with anyone on load.
4. Always apply lever binder in a straight line hook to hook manner without bending and such that handle goes down when securing load.
5. Tighten binders before moving and recheck frequently.
6. Do not exceed working load limit shown on binder—hand effort will tighten binder to working load limit.
7. Do not use cheater bar or handle extension as their use can overload binder system and result in injury.
8. Secure handle down with a positive retaining method.
9. Release handle/load with extreme care. Make sure everyone is clear. Lever binder handle can snap back over center. Use open palm under handle and push up.

* ⚠ WARNING

LOAD BINDING SYSTEMS STORE ENERGY WHICH CAN RELEASE SUDDENLY.

To avoid injury, operate only by hand from a firm standing position. Operate handle cautiously. Stay clear of handle path: handle may release suddenly. Follow instructions.

Poultry lever load binder

- 48355 has 1/4" binder with 18" G43 chain & ring
- 48356 has 1/4" binder with 18" G43 chain and 5/16" G43 Grab Hook

| Chain size (in.) | Chain grade | Working load limit (lbs.)* | Product code | UPC 81767- | Take-up (in.) | Handle length (in.) | Approx. weight each (lbs.) |
|------------------|-------------|----------------------------|--------------|------------|---------------|---------------------|----------------------------|
| 1/4 | G30, 43 | 2,600 | 48355 | 48355 | 2 3/4 | 11 1/4 | 4.7 |
| 1/4 | G30, 43 | 2,600 | 48356 | 48356 | 2 3/4 | 11 1/4 | 4.7 |

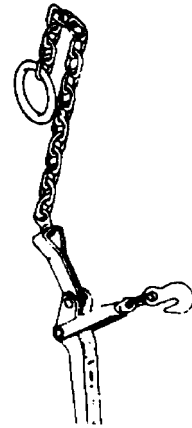

CM malleable lever load binder

- Free turning 360° swivels on both hooks for easier handling and better utility.
- Front tongue for greater take-up.
- Special handle angle prevents finger trap.
- Drop forged, short reach hooks for maximum take-up.
- Meets D.O.T. and C.V.S.A. specifications.

| G30 max. size (in.) | Working load limit (lbs.)* | Product code | UPC 43927- | Take-up (in.) | Handle length (in.) | Approx. weight each (lbs.) |
|---------------------|----------------------------|--------------|------------|---------------|---------------------|----------------------------|
| 1/4 | 2,600 | D48314 | 24252 | 2 3/4 | 11 1/4 | 2 7/8 |
| 3/8 | 5,400 | D48315 | 23029 | 4 1/2 | 16 | 7 3/4 |
| 1/2 | 6,000 | D48316 | 24253 | 4 1/2 | 19 | 11 3/4 |

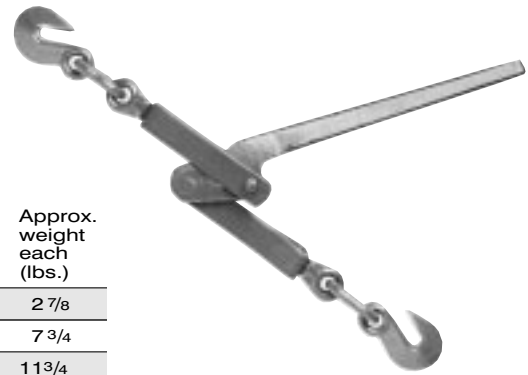

Ratchet type load binder

- Heavy duty, rigid, all steel construction.
- Short reach hooks for maximum take-up.
- Infinite adjustment.
- Continuous take-up.
- Meets D.O.T. and C.V.S.A. specifications.

| Max. size (in.) | | Working load limit (lbs.)* | Product code | UPC 43927- | Take-up (in.) | Approx. weight each (lbs.) |
|-----------------|-----------------|----------------------------|--------------|-----------------|---------------|----------------------------|
| — | | 13,000 | D48363** | 30002 | 8 | 11 |
| 5/16 3/8 | G70 G43 | 5,400 | D48365 | 30003 | 8 | 12 1/4 |
| 3/8 1/2 | G70 G43 | 9,200 | D48366 | 31205 | 8 | 12 1/4 |
| 5/16 3/8 | G70 G43 | 5,400 | D48810 | 21059 | 6 | 7 3/4 |
| 3/8 5/16 | G80, G43 G70 | 7,100 | D48360 | 81767- 48360 | 8 | 13 |
| 1/2 5/8 | G70 G43 | 13,000 | D48367 | 30008 | 8 | 14 |

**Supplied without hooks.



CM tightener load binder

- Features swivel hook for easier operation.
- Either hook may be permanently attached to chain.
- Rugged cast construction with formed hooks.

| Working load limit (lbs.)* | Product code | UPC 43927- | Take-up (in.) | Handle length (in.) | Approx. weight each (lbs.) |
|----------------------------|--------------|------------|---------------|---------------------|----------------------------|
| 375 | D48949 | 31206 | 3 | 9 1/2 | 2 |



Specialty forged lever load binder

| Chain size (in.) | Chain grade | Working load limit (lbs.)* | Product code | UPC 81767- | Take-up (in.) | Handle length (in.) | Approx. weight each (lbs.) |
|------------------|-------------|----------------------------|--------------|------------|---------------|---------------------|----------------------------|
| 3/8 | G30, 43 | 5,400 | 48395 | 48395 | 4 1/2 | 16.62 | 14.6 |
| 5/16 | G70 | 5,400 | 48395 | 48395 | 4 1/2 | 16.62 | 14.6 |

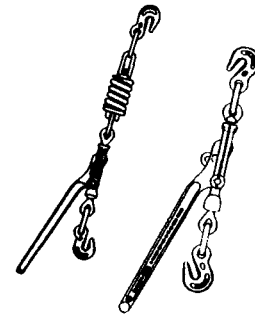

CM drop forged load binder

- All steel.
- Drop forged.
- Both hooks swivel 360°.
- Each binder individually proof tested.
- Tie-down hole in handle.
- Short reach hooks for maximum take-up.
- Heavy, rigid construction.
- Special manufacturing permits use with transport grade 70 chain.
- Meets D.O.T. and C.V.S.A. specifications.

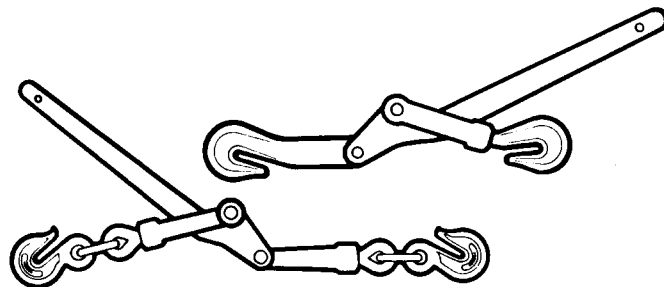

| Working load limit (lbs.)* | Product code | UPC 43927- | Chain grade & size (in.) | | | Handle length (in.) | Take-up (in.) | Approx. weight each (lbs.) |
|----------------------------|--------------|------------|--------------------------|-----|------|---------------------|---------------|----------------------------|
| | | | G30 | G43 | G70 | | | |
| 2,600 | 320104 | 32146 | 1/4 | 1/4 | — | 11 1/4 | 3 | 2 1/2 |
| 5,400 | 320105 | 24251 | 3/8 | 3/8 | 5/16 | 16 1/8 | 4 1/4 | 8 |
| 9,200 | D48306 | 21424 | 1/2 | 1/2 | 3/8 | 16 5/8 | 4 1/2 | 10 |

CM E-Z Pro cam release lever binder

- Provides recoilless CAM release design.
- Entirely hand releasable.
- Individually proof tested.
- Use with grade 43 and grade 70 chain.

| Chain grade & size (in.) | | Working load limit (lbs.)* | Product code | UPC 43927- | Take-up (in.) | Approx. weight each (lbs.) | Std. Pack |
|--------------------------|------|----------------------------|--------------|------------|---------------|----------------------------|-----------|
| G43 | G70 | | | | | | |
| 3/8 | 5/16 | 5,400 | D48405 | 23028 | 4 1/2 | 11 | 4 |

